



110 Fairgrounds Drive • P.O. Box 188 • Manlius, NY 13104-0188 USA • 315.682.9176 • FAX: 315.682.9160

OPERATOR'S MANUAL



Model 70**D** Single and Twin Swing Blade® Rotary Wire Strippers

PRODUCTION WIRE PROCESSING EQUIPMENT



110 Fairgrounds Drive • P.O. Box 188 • Manlius, NY 13104-0188 USA • 315.682.9176 • FAX: 315.682.9160

CARPENTER MODEL 70D ROTARY WIRE STRIPPER SINGLE OR TWIN BLADE OPERATING INSTRUCTIONS

APPLICATION

The Model 70D Rotary Wire Stripper is designed to strip many types of extruded insulations including, PVC, Teflon, Nylon, some Kapton, Kynar, Neoprene and others.

With a **Single Blade Faceplate**, the Model 70D will strip wires up to .201" (5.1mm) overall O.D.

With a **Twin Blade Faceplate**, the Model 70D will strip wires up to .265" (6.7mm) overall O.D.

WIRE GUIDE SELECTION

Select a Wire Guide with the smallest inside diameter that slips freely over the outside diameter of the wire to be stripped.

Standard Wire Guides available (inches):

For Single Blade Face Plate

.028, .032, .036, .040, .046, .052, .059, .067, .076, .086, .098, .110, .120, .136, .152, .169, .185, .201

For Twin Blade Face Plate

.028, .032, .036, .040, .046, .052, .059, .067, .076, .086, .098, .110, .120, .136, .152, .169, .185, .201, .218, .234, .250, .265

#1877 Single Blade Face Plate Assembly

SET UP

Wire Guide Installation: Remove plastic guard. Insert wire guide by aligning hole in wire guide flange with locating pin in face plate. Tighten wire guide locking screw with wrench provided.

Blade Adjustment: Loosen blade block locking screw. Set blade to conductor thickness. To adjust blade "in", turn blade adjusting screw clockwise; to move blade "out" turn counter-clockwise. Hold blade block firmly so that blade adjusting screw is against stop block. Retighten block locking screw.

Face plate may be removed for blade adjustment if desired. Loosen the face plate set screws. Push the face plate out toward you.

When installing face plate into head assembly make certain to keep the wire guide locking screw lined up with clearance hole in head. Re-install plastic guard.

TRIAL STRIP

Adjust stop rod to strip length desired by loosening thumb screw located on the top of the stop rod post. (The stop rod collar is used to offer a larger target when long strips are being utilized. Reverse the stop rod, using the machined end when short strips are desired). Turn the unit on.

Steps:

- A.** Insert wire through wire guide to stop rod (adjusted for strip length).
- B.** Withdraw wire slightly to allow blade to slowly close completely on wire.
- C.** Pause momentarily.
- D.** Withdraw wire sharply.

Note: Cycle time may be shortened as technique is perfected.

Final Blade Adjustment: If blade contacts conductor, move blade adjusting screw clockwise (out). If slug has not been removed, turn counter-clockwise (in). Cut off trial strip and repeat if necessary. Make certain to always retighten blade block locking screw after having made blade adjustments. These adjustments may be made without removing face plate.

PRODUCTION WIRE PROCESSING EQUIPMENT

Visit our website at: www.carpentermfg.com • e-mail address: wire@carpentermfg.com

**MODEL 70D OPERATING
INSTRUCTIONS Cont...****#2500 Twin Blade Face Plate Assembly****SET UP**

Loosen push plate mounting screws and remove push plate. Slip wire guide into face plate. Re-install push plate.

Blade Adjustment: Remove plastic guard. Loosen blade block locking screw. Set blades to conductor thickness. To adjust blades "in", turn blade adjusting screw clockwise; to move blades "out", turn counter-clockwise. Retighten blade block locking screw.

Face plate may be removed for blade adjustment if desired. Remove push plate and loosen the face plate set screws. Push the face plate out toward you.

When installing face plate into head assembly make certain to keep the blade block locking screw and the blade adjusting screw in open view for later adjustments.

Re-install push plate and plastic guard.

TRIAL STRIP

Adjust stop rod to strip length desired by loosening thumb screw located on the top of the stop rod post. (The stop rod collar is used to offer a larger target when long strips are being utilized, Reverse the stop rod, using the machined end when short strips are desired). Turn unit on.

Steps:

- A.** Depress push plate gently with thumb, allowing blades to open just enough to insert wire.
- B.** With other hand, insert wire through wire guide to stop rod (adjusted for strip length).
- C.** Allow blades to close completely on wire by slowly removing pressure on push plate and withdrawing wire slightly as blades grip and sever insulation.
- D.** Pause momentarily with thumb off push plate.
- E.** Withdraw wire sharply.

Note: Cycle time may be shortened as technique is perfected.

Final Blade Adjustment: If blades contact conductor, move blade adjusting screw counter-clockwise. If slug has not been removed, turn clockwise. Cut off trial strip and repeat if necessary. Make certain to always retighten blade block locking screw after having made blade adjustments. These adjustments may be made without removing face plate.

CENTERING BLADES

Blades are factory centered, re-center only after new blades have been installed. Unhook blade block spring, loosen centering lock screw on front of face plate, and blade block locking screw. Insert "pin" end of centering gauge (supplied with machine) through the face plate in the same manner as you would a wire guide. Then turn the blade adjusting screw until both blades make contact with the centering gauge. Tighten blade block lock screw; turn centering screw to contact blade adjusting screw; tighten centering lock screw. Re-hook blade block spring, loosen blade block lock screw and turn blade adjusting screw counter-clockwise to allow the centering gauge to drop out. Retighten blade block lock screw. Re-install face plate, push plate and plastic guard.

CAUTION

Always operate with plastic guard in place over the head assembly. Never insert anything but insulated wire into face plate or blade damage may occur.



110 Fairgrounds Drive • P.O. Box 188 • Manlius, NY 13104-0188 USA • 315.682.9176 • FAX: 315.682.9160

WARRANTY

Carpenter Mfg. Co., Inc. manufactures its products to be free from defects in materials and workmanship. Should any defect occur within 1 year after shipment, Carpenter Mfg. Co., Inc. will at its option, exchange or repair the defective device.

Repairs or adjustments to equipment under warranty can be performed at our factory or at the customer location, at the option of Carpenter Mfg. Co., Inc. In most cases a 1-2 day turn around time will be necessary to repair equipment at our facility. When equipment is returned to our factory for repair or replacement, freight charges will be borne by the customer. Repaired or replaced equipment will be returned at Carpenter's expense via U.P.S. ground service. If alternate shipping is requested by the customer, the difference in shipping charges will be billed to the customer.

This is a limited warranty and is in lieu of all other representations and expressed and implied warranties (including the implied warranties of merchantability and fitness for use.) Under no circumstances shall Carpenter Mfg. Co., Inc. be liable for any incidental or consequential property damages or losses subsequent to misuse or improper maintenance of this equipment.

Not covered by this warranty are:

- Consumable parts (blades, Rollers, guides, springs, inserts, stripping wheels, etc.).
- Cosmetic problems (nicks, scratches, etc.).
- Damages caused by any repairs or modifications by unauthorized personnel.
- Abuse.
- Damage caused by shipping.
- Damage caused by environmental and/or atmospheric conditions.

PRODUCTION WIRE PROCESSING EQUIPMENT

Visit our website at: www.carpentermfg.com • e-mail address: wire@carpentermfg.com

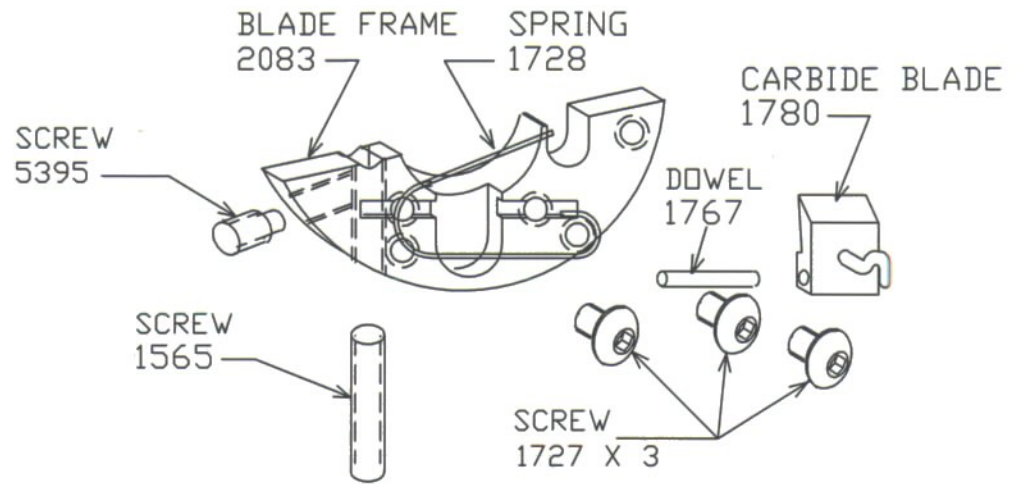
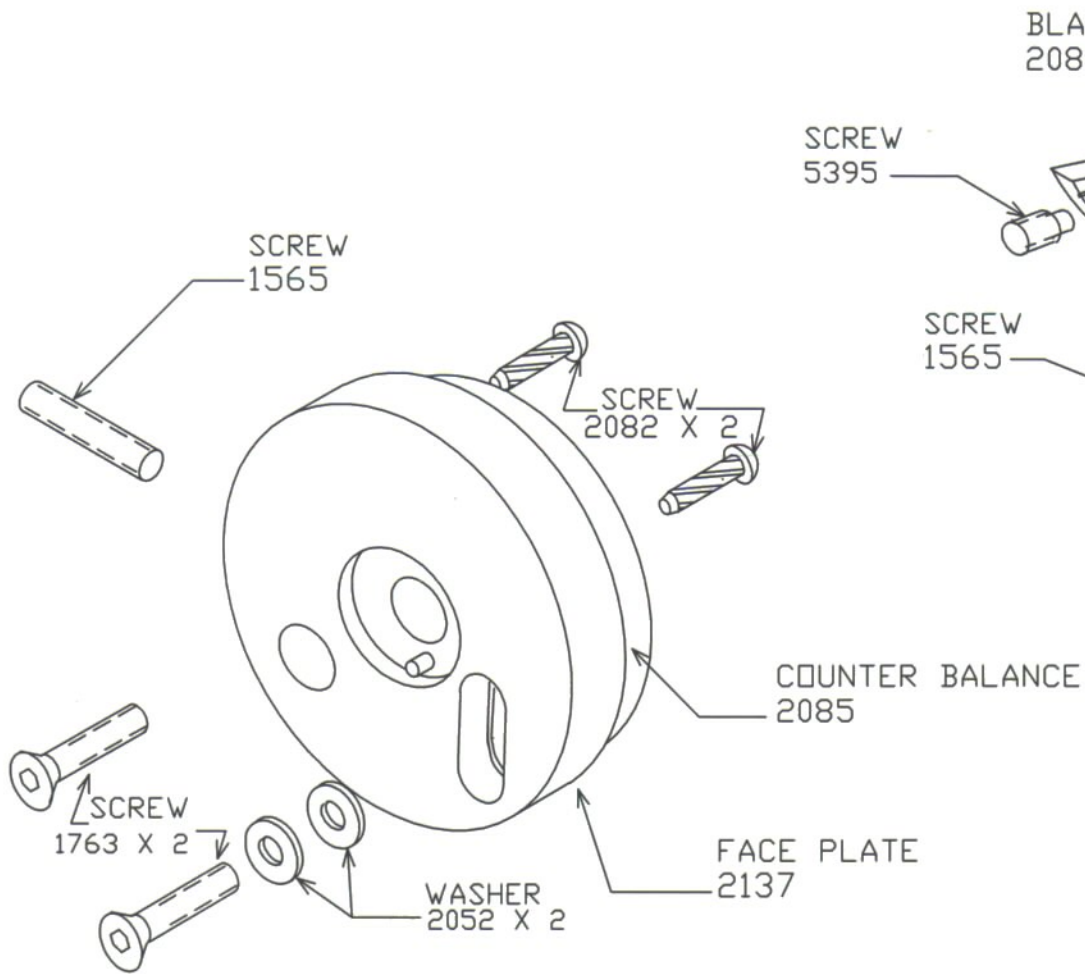

SINGLE BLADE
FACE PLATE ASS'Y
1877
1/20/00

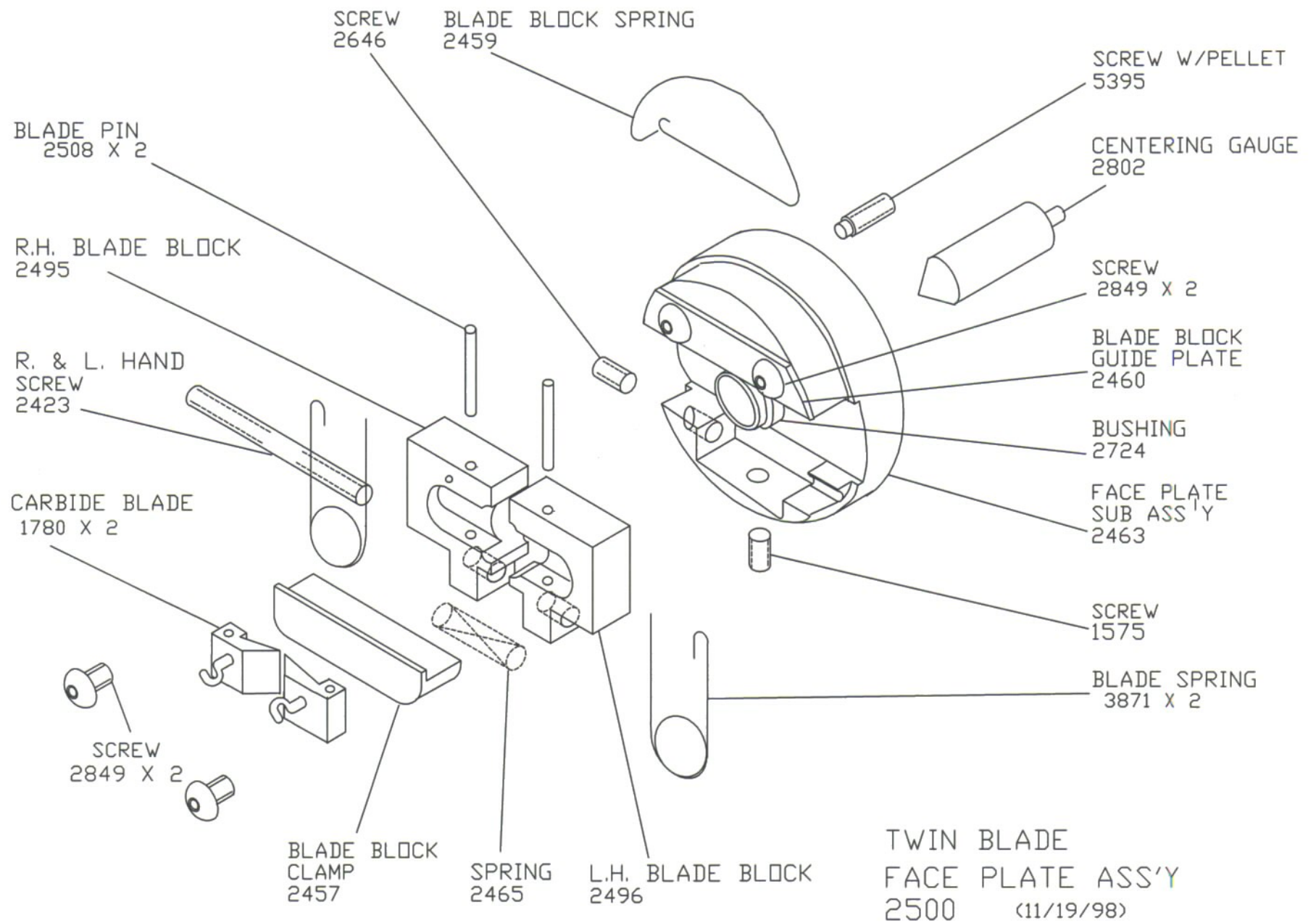

SPRING
1887 X 2
SCREW
1506 X 4

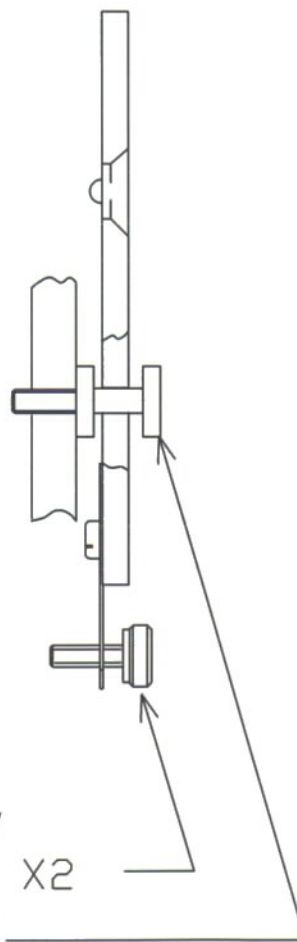
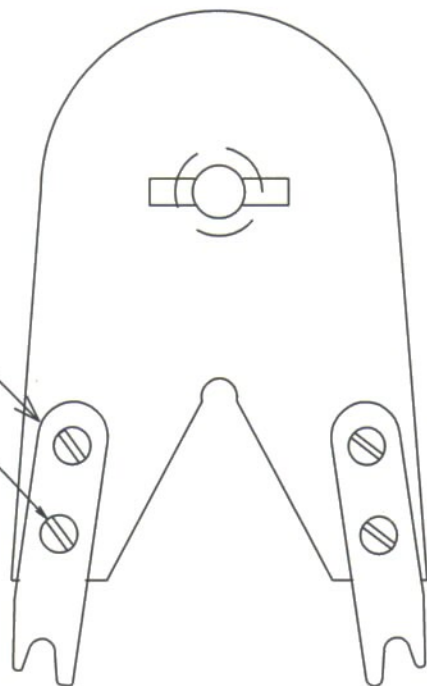

SCREW
3877 X2
3448
PUSH PLATE STOP

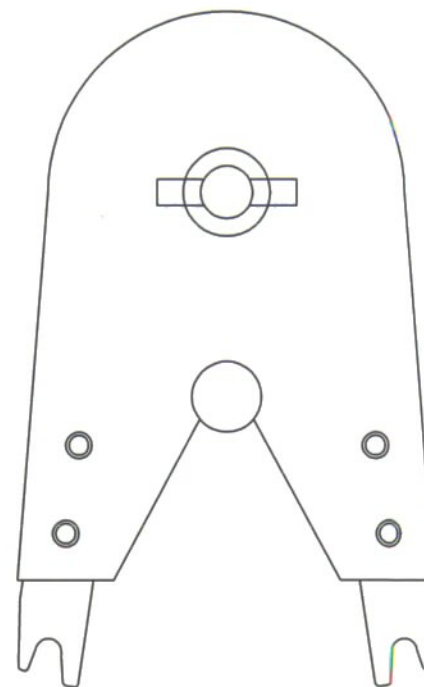

1980

PUSH PLATE ASS'Y
(1980PPA)

3/8/00

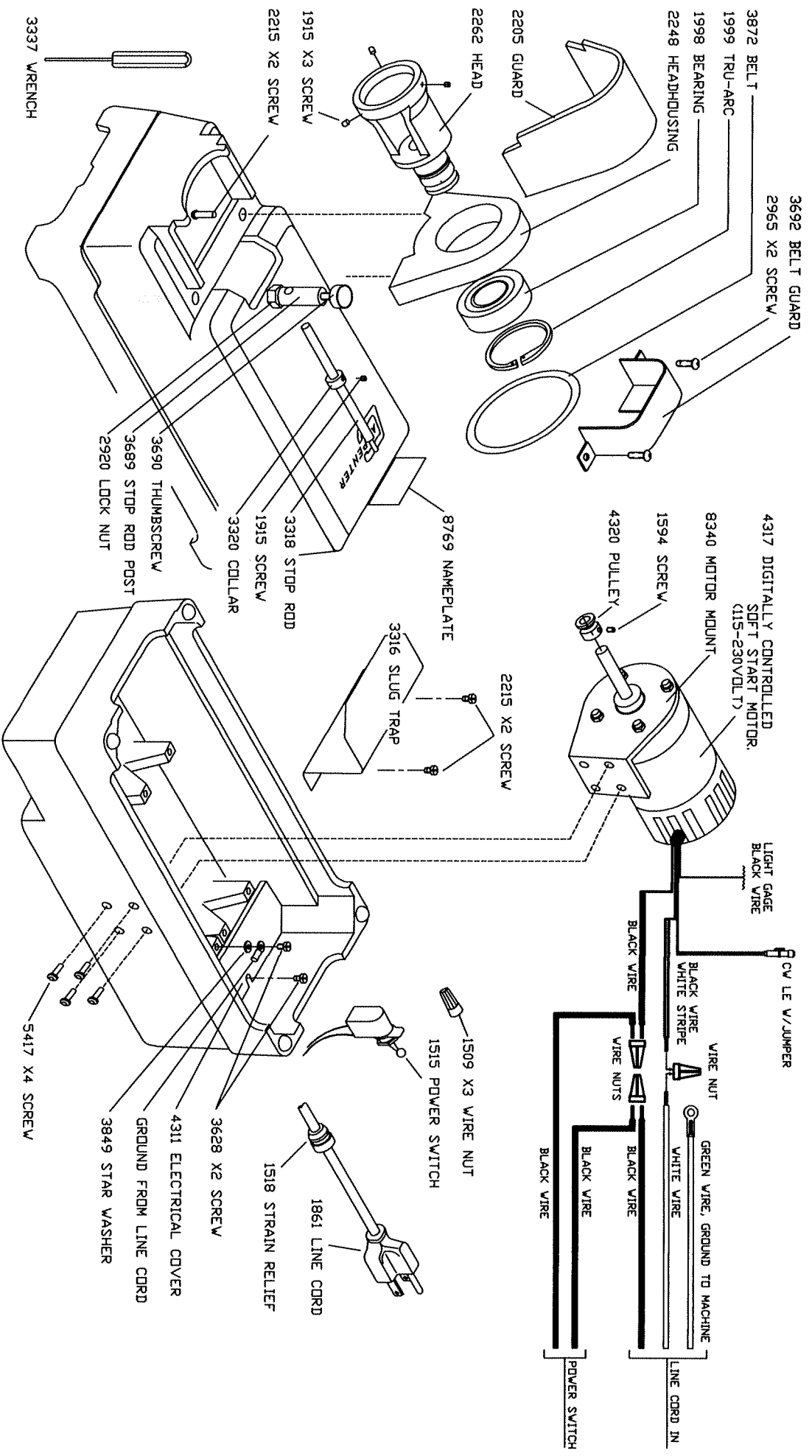

M70D
6/9/17