

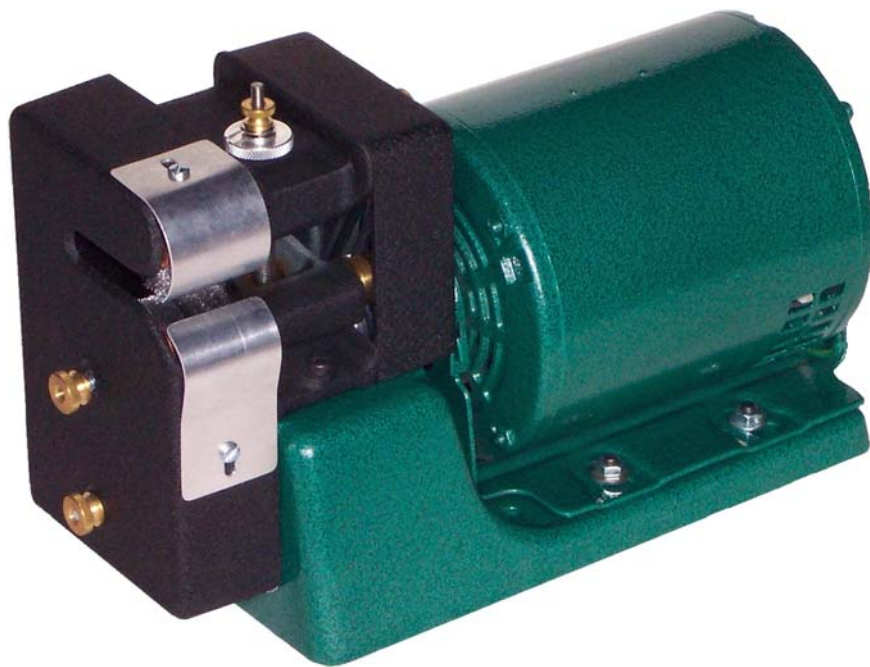

110 Fairgrounds Drive • P.O. Box 188 • Manlius, NY 13104-0188 USA • 315.682.9176 • FAX: 315.682.9160

OPERATOR'S MANUAL



Model 14B Magnet Wire Stripper

PRODUCTION WIRE PROCESSING EQUIPMENT

CARPENTER MODEL 14B MAGNET WIRE STRIPPER

INTRODUCTION

Thank you for choosing Carpenter Mfg. Co. Inc. Wire Processing Equipment. For over 50 years Carpenter has been a leader in Wire Processing Technology and Service. Our desire has always been to bring you reliable products. We look forward to a long healthy relationship with you and our company.

The MODEL 14B can process a wide range of wire as referenced on the following page.

These processing specifications are based upon the most commonly manufactured wire. Special applications may arise with wires that are within the specification limits of the machine but are very difficult or unsuccessful to process. Likewise, wires that exceed the specified limits of the machine can sometimes be processed. Because there are many variables involved in Wire Processing we strongly recommend a free Wire Evaluation at our factory followed by a demonstration from a Carpenter representative to insure the ultimate success of your Wire Processing Application.

This operating manual explains how to operate the MODEL 14B. To ensure the best performance of your machine, read this manual carefully until you familiarize yourself thoroughly with its operation and features. After you have read through the manual, keep it available for reference. If you have any questions about this machine or service please let us know. Our phone number is 315.682.9176, fax number 315.682.9160. Website: www.carpentermfg.com, E-mail: wire@carpentermfg.com.

CARPENTER MODEL 14B MAGNET WIRE STRIPPER

IMPORTANT NOTICE

The products in this shipment left our facility in good working condition. Their safe delivery is the responsibility of the carrier that delivered this shipment to you.

Our stated shipping terms are F.O.B. our facility at 110 Fairgrounds Drive, Manlius, NY 13104.

According to applicable laws, the responsibility for this shipment was transferred to you as soon as the carrier accepted the goods at our warehouse.

If concealed damage is discovered after unpacking this shipment, you must submit a damaged freight claim with the carrier. Carpenter Mfg. Co., Inc. cannot submit your claim for you.

In order for you to collect for concealed damage, the carrier must be notified with 5 days of the date you receive this shipment.

You must leave the damaged items and packing material as is (i.e. return all merchandise and all packing material to the shipping container) until the claim has been inspected by the carrier.

Also, the carrier will not accept a claim if the goods have been moved from the point of the carriers delivery to another street address.

If you have any questions or problems, please give us a call at 315.682.9176.

CARPENTER MODEL 14B MAGNET WIRE STRIPPER

APPLICATION

The Model 14B is designed to strip Film Type Insulation from large gauge Round and Rectangular Wire using Fiberglass Stripping Wheels or Wire Brush Stripping Wheels.
The Model 14B may also be used with Nylon Brush Wheels for combing out braided or wrapped shielding on Coaxial Cable.

SAFETY GUARDING

The Model 14B comes equipped with Stripping Wheel and Drive Belt guarding. ****IMPORTANT** DO NOT ATTEMPT TO DEFEAT THE FUNCTION OR PURPOSE OF THESE SAFETY GUARDS. SERIOUS INJURY TO THE OPERATOR'S EYES, FINGERS OR OTHER BODY PARTS MAY RESULT FROM ATTEMPTS TO OPERATE THE MODEL 14B WITHOUT THE SAFETY GUARDS.**

WHEEL ADJUSTMENTS

The Model 14B has a telescoping adjustment screw designed to maintain wheel pressure once it has been set. This allows the space between the wheels to be changed without disrupting the preset stripping wheel pressure. Proper wheel pressure along with correct spacing allows for optimum stripping results. Excessive pressure tends to clog the wheels, while too little pressure results in incomplete or slow stripping.

The two adjustments required for set up on the Model 14B are:

1. **#1684** Adjusting Screw – This screw adjusts the distance between the Stripping Wheels. Turning the screw clockwise increases the spacing and counter-clockwise reduces it.
2. **# 1483** Thumb Nut – This nut adjusts the pressure on the Stripping Wheels as you insert the wire. Turning the nut clockwise increases the pressure and counter-clockwise reduces it.

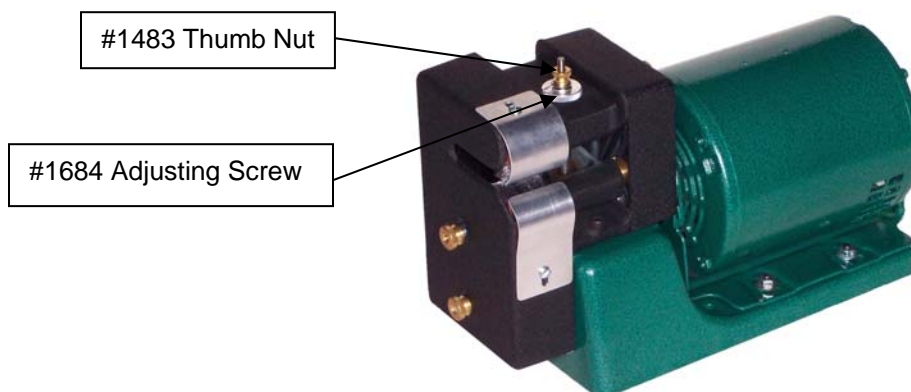

CARPENTER MODEL 14B MAGNET WIRE STRIPPER

Cont.

MACHINE SET UP

Turn the power switch off and unplug the machine from the power source. Turn **#1684** Adjusting Screw clockwise to open up the distance between the stripping wheels. Turn **#1483** Thumb Nut counter-clockwise to reduce the spring pressure applied to the stripping wheels. Insert the wire to strip between the stripping wheels, turn **#1684** Adjusting Screw counter-clockwise until the wheels firmly grip the wire. Once the adjustment is made withdraw the wire from between the stripping wheels. Plug the machine back into the power source and turn the switch on. Make a test strip. If the insulation has not been completely removed, adjust **#1483** Thumb Nut clockwise to increase the stripping wheel pressure. NOTE: Excessive pressure may cause pre-mature wear of the stripping wheels. It may also make it difficult to hold onto the wire during the stripping process.

MACHINE OPERATION

Feed the wire straight in between the wheels slowly and withdraw. Rotate wire 90 degrees and repeat as required. You may also feed the wire into the wheels from the side and pull it toward you. Rotate wire 90 degrees and repeat as required. A **#2998** Wheel Dresser has been provided for machines using Fiberglass Stripping Wheels. This should be used periodically to clean the surface of the stripping wheels and maintain maximum stripping effectiveness. Use this in the same manner as you would to strip wire.

WHEEL CHANGE

1. Unplug machine from power source.
2. Remove **#1486** Wheel Cover.
3. Turn upper wheel nut clockwise and lower wheel nut counter-clockwise to remove.
4. Remove wheels.
5. Install new wheels and reverse process.

CARPENTER MODEL 14B MAGNET WIRE STRIPPER

WARRANTY

Carpenter Mfg. Co., Inc. manufactures its products to be free from defects in materials and workmanship. Should any defect occur within 1 year after shipment, Carpenter Mfg. Co., Inc. will at its option, exchange or repair the defective device.

Repairs or adjustments to equipment under warranty can be performed at our factory or at the customer location, at the option of Carpenter Mfg. Co., Inc. In most cases a 1-2 day turn around time will be necessary to repair equipment at our facility. When equipment is returned to our factory for repair or replacement, freight charges will be borne by the customer. Repaired or replaced equipment will be returned at Carpenter's expense via U.P.S. ground service. If alternate shipping is requested by the customer, the difference in shipping charges will be billed to the customer.

This is a limited warranty and is in lieu of all other representations and expressed and implied warranties (including the implied warranties of merchantability and fitness for use.) Under no circumstances shall Carpenter Mfg. Co., Inc. be liable for any incidental or consequential property damages or losses subsequent to misuse or improper maintenance of this equipment.

Not covered by this warranty are:

- Consumable parts (blades, belts, guides, springs, inserts, stripping wheels, etc.)
- Cosmetic problems (nicks, scratches, etc.)
- Damages caused by any repairs or modifications by unauthorized personnel
- Abuse
- Damage caused by shipping
- Damage caused by environmental and/or atmospheric conditions.

This warranty covers the following machine:

Model #: _____

Shipping Date: _____

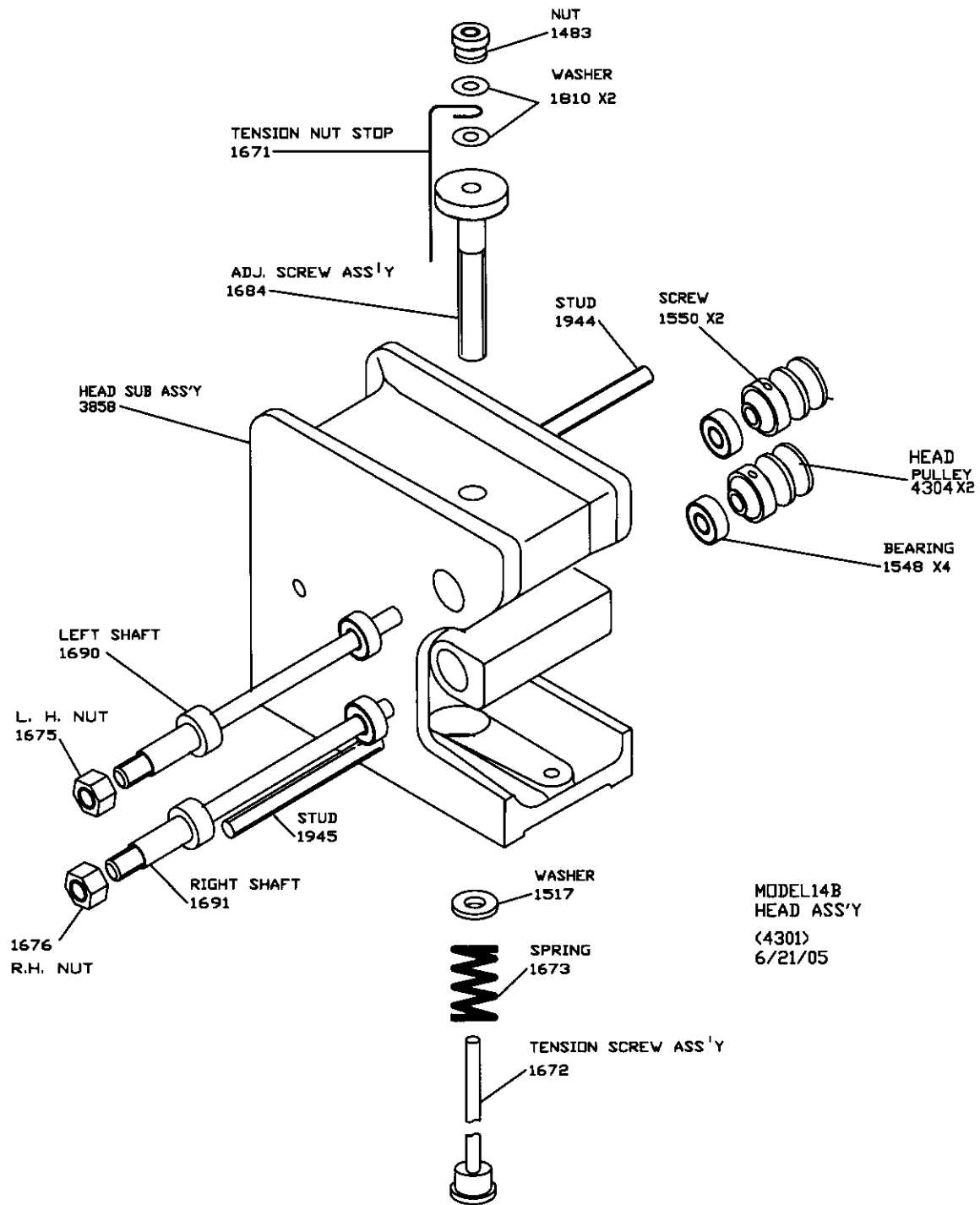

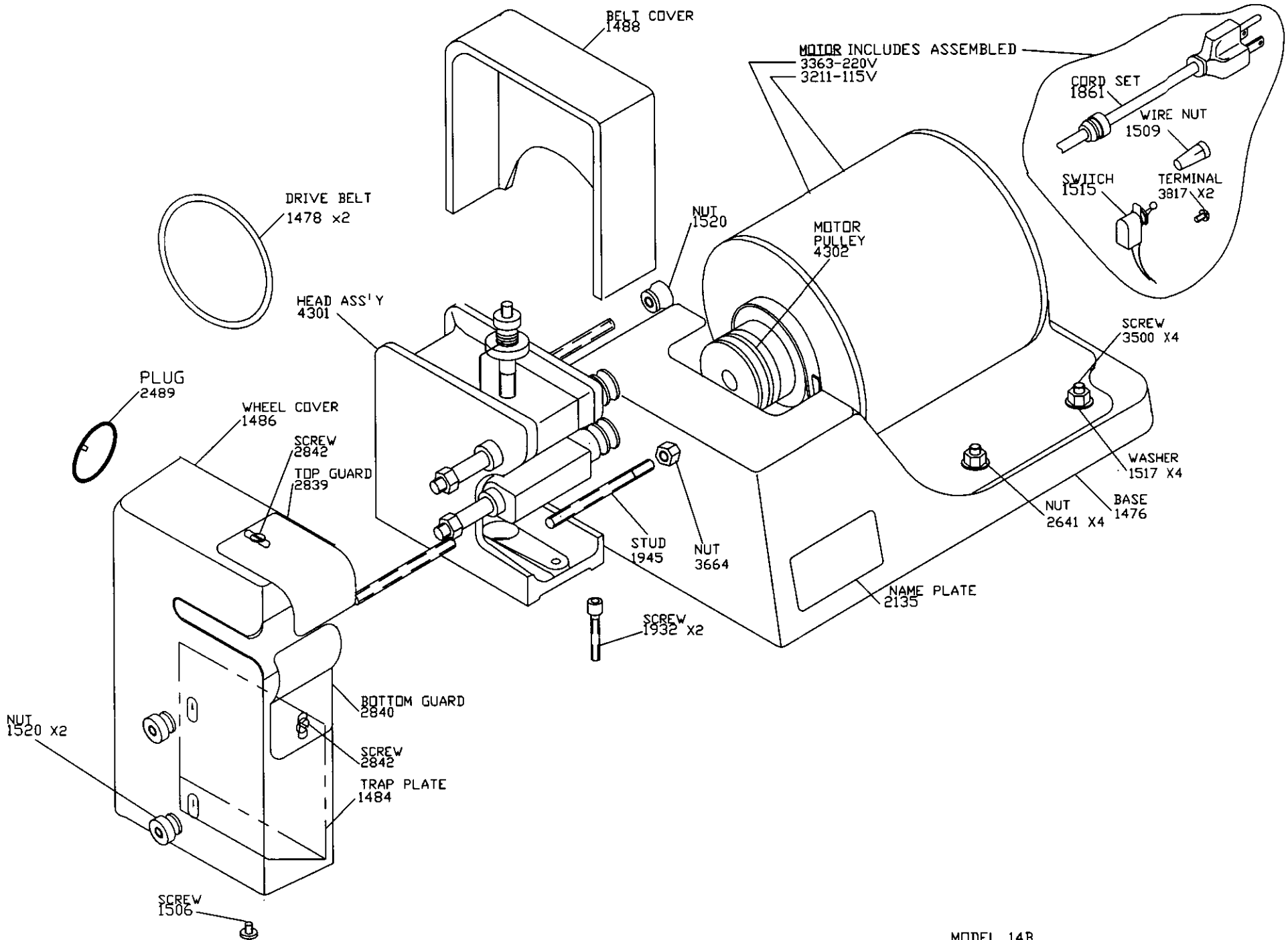

MODEL 14B

(M14B)

3/27/08